

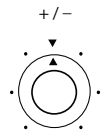

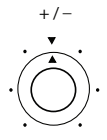

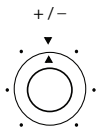

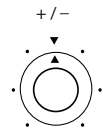

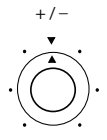
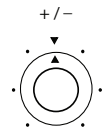









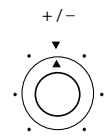
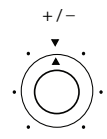
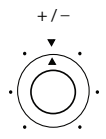
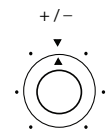
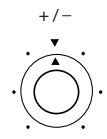
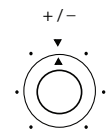

CharterOak PEQ1 | RECALL SHEET |

LOW CUT IN  OUT							GAIN TRIM  LEFT
EQ IN  OUT	 20/60/40	 80/120	 400/800/630	 1k/3k/2k	 5k/8k	 15k/50kL/20k	GAIN TRIM  RIGHT

CharterOak PEQ-1



DATE: PROJECT:
STUDIO: ARTIST:
SONG: LOG:
NOTES:

LOW CUT IN  OUT							GAIN TRIM  LEFT
EQ IN  OUT	 20/60/40	 80/120	 400/800/630	 1k/3k/2k	 5k/8k	 15k/50kL/20k	GAIN TRIM  RIGHT

CharterOak PEQ-1



DATE: PROJECT:
STUDIO: ARTIST:
SONG: LOG:
NOTES: